



# SET-UP SHEET

DRIVER: \_\_\_\_\_

DATE: \_\_\_\_\_

EVENT: \_\_\_\_\_



## FRONT SUSPENSION

FRONT SPINDLE CARRIERS:  25°,  30°

TOE-IN /  TOE-OUT: \_\_\_\_\_°

FRONT RIDE HEIGHT: \_\_\_\_\_

FRONT CAMBER: ± \_\_\_\_\_°

SWAY BAR:  NO,  YES: \_\_\_\_\_

NOTES:

|                        |                                   |                                   |
|------------------------|-----------------------------------|-----------------------------------|
| FRONT SHOCKS           | <input type="checkbox"/> ORIGINAL | <input type="checkbox"/> BIG BORE |
| OIL: _____             |                                   |                                   |
| PISTON: _____          | <input type="checkbox"/> DRILLED  | <input type="checkbox"/> STANDARD |
| SPRING: _____          | STROKE: _____                     |                                   |
| LIMITER: INSIDE: _____ | OUTSIDE: _____                    |                                   |

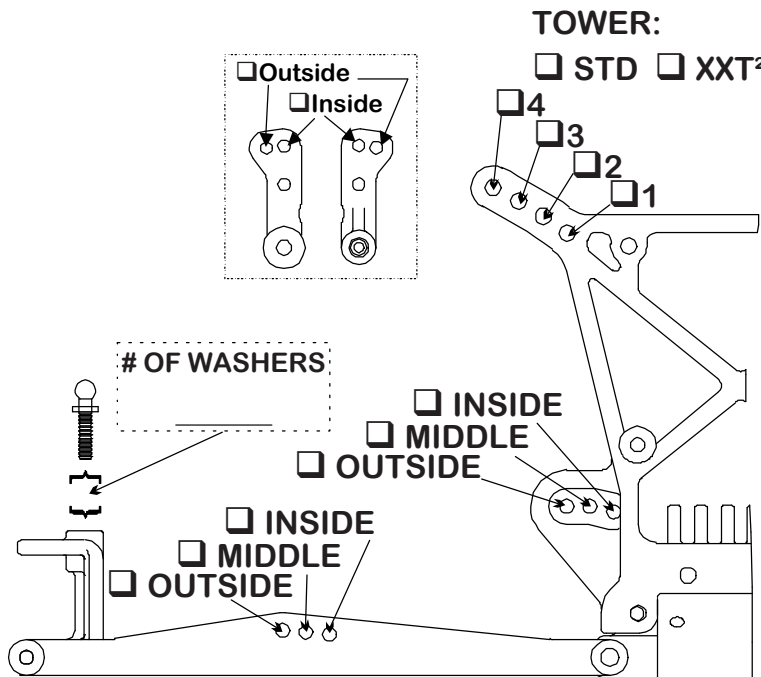

## REAR SUSPENSION

ANTI-SQUAT: \_\_\_\_\_ TOE-IN: \_\_\_\_\_°

REAR RIDE HEIGHT: \_\_\_\_\_

REAR CAMBER: ± \_\_\_\_\_°

SWAY BAR:  NO,  YES: \_\_\_\_\_

DRIVE SHAFTS:  CVDs,  UNIVERSAL

NOTES:

|                        |                                   |                                   |
|------------------------|-----------------------------------|-----------------------------------|
| REAR SHOCKS            | <input type="checkbox"/> ORIGINAL | <input type="checkbox"/> BIG BORE |
| OIL: _____             |                                   |                                   |
| PISTON: _____          | <input type="checkbox"/> DRILLED  | <input type="checkbox"/> STANDARD |
| SPRING: _____          | STROKE: _____                     |                                   |
| LIMITER: INSIDE: _____ | OUTSIDE: _____                    |                                   |

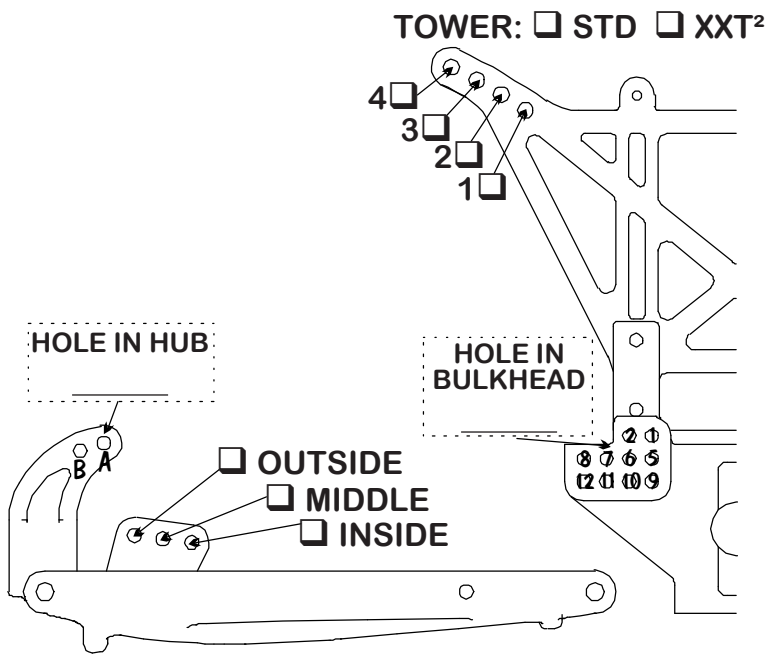

## TRANSMISSION & CHASSIS

FRONT TIRE: \_\_\_\_\_ COMPOUND: \_\_\_\_\_ TRANSMISSION:  2.19,  2.61

REAR TIRE: \_\_\_\_\_ COMPOUND: \_\_\_\_\_ MOTOR: \_\_\_\_\_

CHASSIS:  SHORT,  STANDARD,  LONG,  X-LONG PINION: \_\_\_\_\_ SPUR: \_\_\_\_\_

BATTERY: \_\_\_\_\_ LOCATION: \_\_\_\_\_ MOUNT: \_\_\_\_\_

NOTES: