

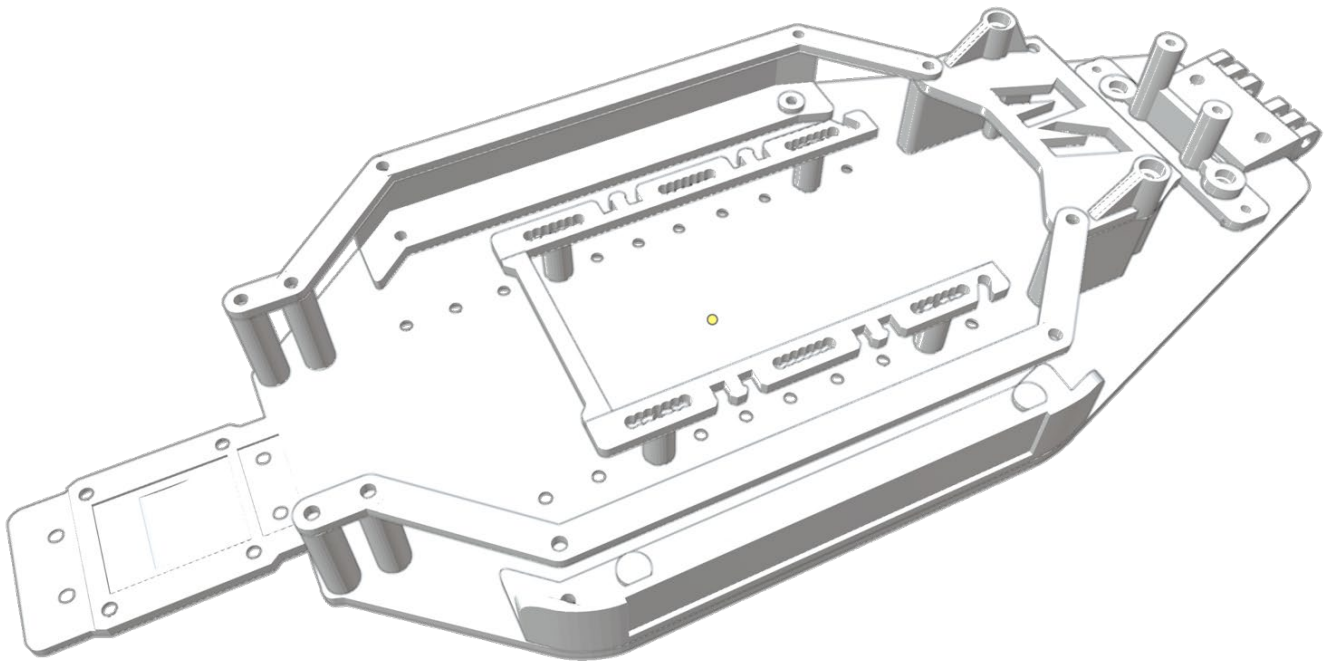

1/10th Scale 2wd Electric Vintage Off Road Racing Truck Upgrade Kit



XXT²

Owner's Manual





Welcome MV XXT² Owner

Thank You for Your Purchase!

We're thrilled that you have purchased the new *Modern Vintage XXT²* upgrade kit for your Team Losi XXT vehicle. From the beginning, we set off to design, test, build and offer the racing community a vehicle that first and foremost honored the original design, but also preserved all of the geometric features of the vehicle. Much like the XXT², the XXT² has gone through extensive design and testing iterations aimed at maximizing tunability across a range of modern and old school surfaces. We focused on improving the ease of maintenance and incorporated unprecedented features that support either a fully vintage or a modern racer! The XXT² is designed with precision, durability, and innovation in mind — built to deliver pure excitement on every track, and it's 100% designed and manufactured in the USA!

Whether you're racing competitively or just having fun, we're confident it will exceed your expectations.



Jose Zayas

Owner Z3D

<https://www.z3dparts.com/>



Dan McDade

Owner DPRC

<https://www.dragonpunchrc.com/>

Join the Community

Share your setup, connect with other enthusiasts, and get the latest updates by following us:

- **Facebook:** <https://www.facebook.com/ModernVintageRC>
- **YouTube:** <https://www.youtube.com/@ModernVintageRC>

We couldn't have done this without our partners in the RC Community!

- Boki: <https://www.bokiracing.com/>
- PVTR: <https://www.facebook.com/RacePVTR>
- Sabula Tech: <https://store.sabulatech.com/>
- Old School RC: <https://www.facebook.com/groups/327432447450585>

Thank you again for being part of the journey — now go unleash your XXT² and **feel the power of precision!**



SET-UP SHEET

DRIVER: _____
 DATE: _____
 EVENT: _____



FRONT SUSPENSION

FRONT SPINDLE CARRIERS: 25°, 30°
 TOE-IN / TOE-OUT: _____ °
 FRONT RIDE HEIGHT: _____
 FRONT CAMBER: ± _____ °
 SWAY BAR: NO, YES: _____

NOTES: _____

FRONT SHOCKS ORIGINAL BIG BORE
 OIL: _____
 PISTON: DRILLED STANDARD
 SPRING: _____ STROKE: _____
 LIMITER: INSIDE: _____ OUTSIDE: _____

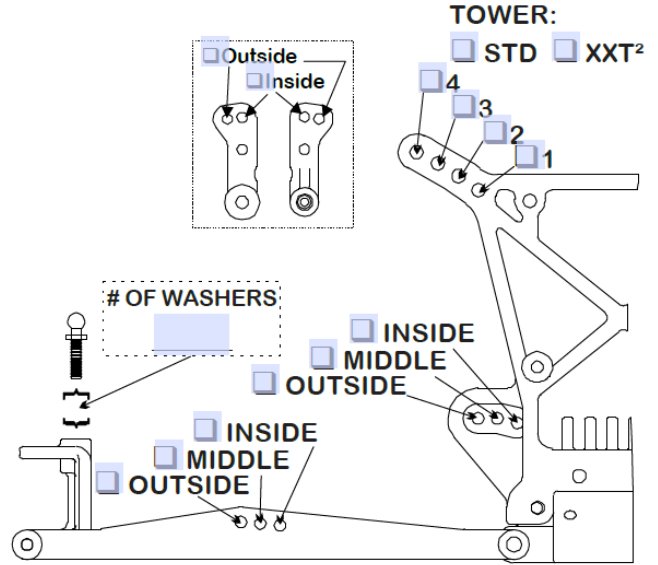

REAR SUSPENSION

ANTI-SQUAT: _____ TOE-IN: _____ °
 REAR RIDE HEIGHT: _____
 REAR CAMBER: ± _____ °
 SWAY BAR: NO, YES: _____
 DRIVE SHAFTS: CVDs, UNIVERSAL

NOTES: _____

REAR SHOCKS ORIGINAL BIG BORE
 OIL: _____
 PISTON: DRILLED STANDARD
 SPRING: _____ STROKE: _____
 LIMITER: INSIDE: _____ OUTSIDE: _____

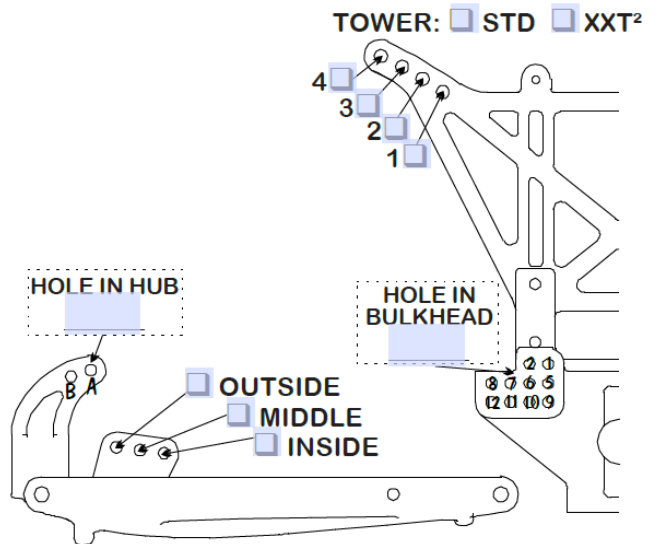

TRANSMISSION & CHASSIS

FRONT TIRE: _____ COMPOUND: _____ TRANSMISSION: 2.19, 2.61
 REAR TIRE: _____ COMPOUND: _____ MOTOR: _____
 CHASSIS: SHORT, STANDARD, LONG, X-LONG PINION: _____ SPUR: _____
 BATTERY: _____ LOCATION: _____ MOUNT: _____

NOTES: _____



Table of Contents

1. Specifications	5
2. Package Contents.....	6
3. Instructions	7
4. Mounting Electronics on your XXT²	11
5. XXT² Battery Mounting Options.....	11
6. XXT² Body	12
7. XXT² Elite Kit.....	13
8. Finished!.....	14
9. Addendum from the Team Losi XXT CR Manual.....	15

Getting Started

- **Unbox Carefully:** Make sure all components and accessories are included.
- **Review the Manual:** Familiarize yourself with the various parts, assembly tips, tools needed, and safety information.
- **Take Your Time:** Success starts now. Be patient and follow the manual and suggestions.



1. Specifications

Thank you for purchasing the XXT² Carbon Line RC Truck. This manual provides instructions for building, setup, and maintenance to ensure long-term performance and fun.

MV XXT² Specifications

The XXT² Carbon Line is a high-performance 1/10 scale RC car designed for both racing and recreational use.

Chassis Length: 15.5" – 393.7mm	Wheelbase: 11.4" – 289.5mm	Front Track Width** : 12.5" – 317.5mm
Weight w/out Tires* : ~1450g	Height** : 5.5" – 140mm	Rear Track Width** : 12.6" – 320mm

*Final weight will vary depending on accessories and battery used

**All measurements taken at a 20mm ride height

Parts Needed

Parts needed will vary if you are building a XXT² “Essentials” or a “Pro” build.

- Team Losi XXT or XXTCR Kit
- Electronics (ESC, Motor, Servo, Battery, Radio)
- Tires and wheels

Tools Needed

- Needle-nose Pliers
- 1/16" Allen Wrench
- 1/8" Allen Wrench
- 2.5mm Allen Wrench
- 3/16 Nut Driver
- 5.5mm Nut Driver
- Other tools might be needed for Losi XX disassembly. These include but not limited to:
 - ¼" Nut Driver
 - 3/8" Nut Driver
 - Hobby Knife
 - Soldering Iron

Safety Information and Best Practice

- Always build and use under adult supervision.
- Exercise care when using hand tools, sharp instruments or power tools.
- Avoid water and high-traffic areas.
- Disconnect the battery after use.



2. Package Contents

MV XXT² Essential Kit Content

Carbon Fiber Parts (Qty.)	Carbon Infused Parts (Qty.)	Hardware (Qty.)	Accessories (Qty.)*
Chassis (1)	Side Guards (2)	Long Aluminum Standoffs (4)	Battery O-rings (3)
Top Deck (2)	Servo Mounts (2)	Med. Aluminum Standoffs (4)	Battery O-rings (2)
Battery Brace (1)	Chassis Supports (2)	Short Aluminum Standoffs (4)	ST Front Bulkhead (1)
Battery Tabs (4)	Steering Bellcrank (1)	Front Bulkhead Hingepin (1)	Boki XXT ² Body (1)
	Pivot Coupler (1)		Boki Gear Cover (1)

Note: All Carbon infused parts have been hand-threaded for you to ensure optimal installation

MV XXT² Essential Hardware Kit

Flat Head (Qty.)	Button Head (Qty.)	Socket Cap (Qty.)	Washers/Nut (Qty.)
8/32 x .3" (3)	4-40 x .5" (8)	N/A	Countersunk Washer (6)
4-40 x .5" (20)	4-40 x .875" (2)		4-40 Nut (2)
4-40 x .375" (16)			

MV XXT² Founders/Pro Kit Content (Optional)

Thank you for purchasing the MV XXT² Pro kit, below are the additional parts included to further improve the performance of your vehicle. The "Pro" kit offers unprecedented tuning options for your XXT² allowing you to take your vintage racer to the next level. Highlights include: the 2-n-1 rear tower so you can easily install Big Bore shocks on your vehicle, a motor centering kit to improve side-to-side weight distribution, adjustable carbon chassis stiffener, as well as a titanium front cross brace and a fan mount to keep your motor cool!

MV XXT² Pro Kit Content

Carbon Fiber Parts (Qty.)	Carbon Infused Parts (Qty.)	Hardware (Qty.)	Accessories (Qty.)*
Front Tower (1)	Chassis Brace (1)	Tit. Front Cross Brace (1)	XXT ² Chassis Skin (1)
Rear 2-n-1 Tower (1)	Bumper (1)		
Tranny Brace (1)	Rear Fan Mount (1)		
Chassis Stiffener (1)	Motor Centering Kit (1)		
	2-n-1 Rear Tower Brace (1)		

Note: All Carbon infused parts have been hand-threaded for you to ensure optimal installation

MV XXT² Pro Hardware Kit

Flat Head (Qty.)	Button Head (Qty.)	Socket Cap (Qty.)	Washers/Nut (Qty.)
	M3 x 12mm (3)	4-40 x .5" (10)	M3 Nut (3)
		4-40 x 1.5" (3)	4-40 (2)
		4-40 x 3/4" (2)	



3. Instructions

Getting Started

Before beginning your MV XXT² build, we suggest you disassemble your Team Losi XXT vehicle, and evaluate, repair and/or rebuild all of your racing components. This is a great opportunity to go through all of your critical suspension, transmission and hardware (bearings, hinge pins, ...) components. Keep in mind that the preparations starts at the bench; it will pay dividends on the track!

- Key Components Needed
 - Rear Suspension Components (i.e. arms, hubs, pivot blocks, bulkhead, ...)
 - Entire Drivetrain (i.e. gearbox, motor plate, ...)
 - Rear Tower (Not needed with Pro Kit)
 - Turnbuckles and Hingepins
 - Front Suspension Components (i.e. arms, bellcrank, caster blocks, chassis brace, ...)
 - Shocks (Optional Big Bore setup with Pro Kit. Shocks not included)
 - Front Tower (Not needed with Pro Kit)

Building The XXT²

Before beginning your XXT² build, please review the parts included and organize your components and hardware. Please be sure to follow the instructions as outlined within the manual, as we have carefully developed the approach and order to facilitate your experience with the build. There will be several instances where we will provide you with an “Optional” step. For all of those instances, the “Option” will be explained for you to determine the most suitable choice for you!

XXT² Main Chassis Build (Rear):

- Step 1:** Let's get started! Separate your chassis and both the “Essential” screw kit and standoffs by size.

- **Step 2:** Tighten the 4 long standoffs (.9375") with the supplied 4-40 x .5" flat head screws. **Note:** We suggest using a small amount of blue Loctite on the screws.
- **Step 3:** Install both the left and right-side guards with the supplied 4-40 x .5" (Qty. 4) flat head screws. Tighten the screws all the way. **Note:** Screws may not fully tighten, they will be secured with the standoffs.

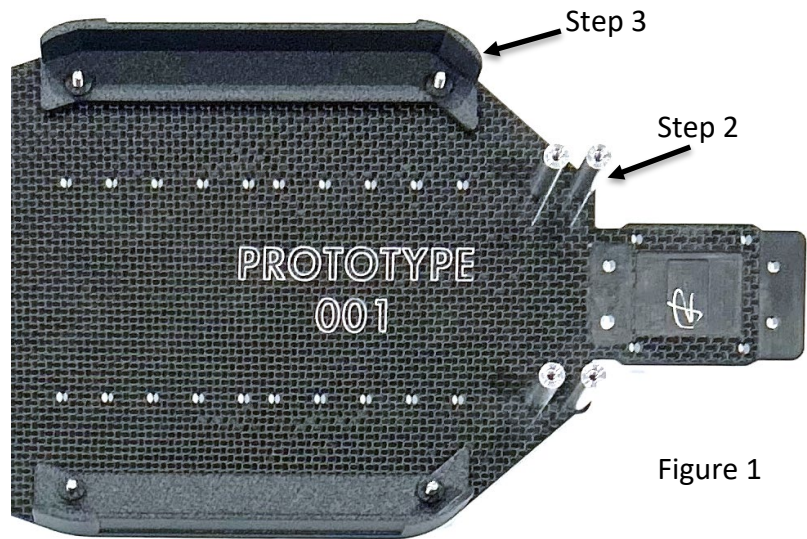

Figure 1

- **Step 4:** Tighten the 4 medium standoffs (.75") onto the side guards. **Note:** We suggest using a small amount of blue Loctite on the screws.

XXT² Main Chassis Build (Front):

- **Step 5:** Install both center chassis supports with the supplied 4-40 x .5" (Qty. 4) flat head screws. Tighten the screws all the way.
- **Step 6a:** Install the bellcrank adapter with the supplied 4-40 x .5" (Qty. 2) flat head screws on the middle two holes. Tighten the screws all the way. **Note:** The bellcrank adapter needs to be installed with the taller support on the left side, see Figure 2
- **Step 6b:** Secure the outer two mounts on the bellcrank adapter using the supplied 4-40 x .375" (Qty. 2) flat head screws. Tighten the screws all the way and finish with the supplied 4-40 lock nuts.

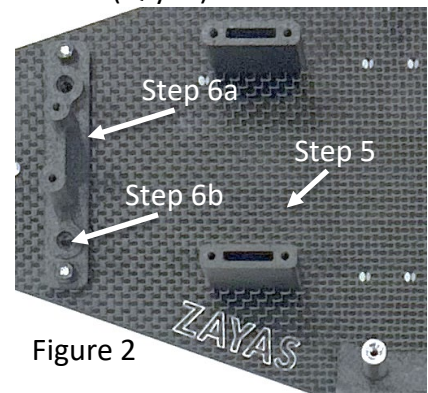

Figure 2

- **Step 7:** The Sabula Tech front bulkhead comes preassembled with the pivot coupler using the DPRC titanium hinge pin. Install the front-end bulkhead assembly with the supplied 8-32 x .3" (Qty. 3) flat head screws. Tighten the screws all the way.
- **Step 8:** Pivot the front bulkhead downward and secure the front shock tower using your original 4-40 screws. Tighten screws all the way. **Note:** If you purchased the "Pro" kit use the new front tower. The XXT² front tower goes on the backside of the bulkhead. Use the supplied 4-40 x .5" (Qty. 4) socket cap screws.

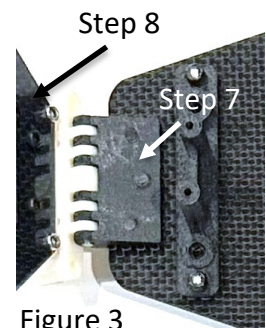
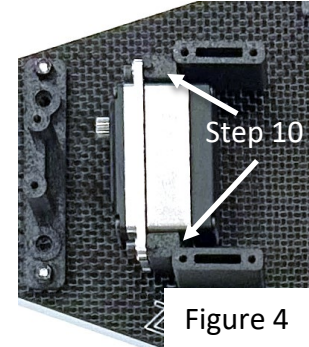

Figure 3

- ❑ **Step 9:** Install your original front arms using your original hinge pins, e-clips and cross brace.
Note: If you purchased the “Pro” kit, use the new titanium front cross brace.

XXT² Servo and Steering Assembly:

- ❑ **Step 10:** Secure both the left and right servo mounts onto your servo using your original 4-40 screws. See Figure 4 for servo mount orientation. **Note:** On your new XXT², you no longer have to cut your bottom servo ears. If you want to use screws on the bottom servo hole, make sure it is a short screw (.375”) to not interfere with the chassis mount hole.



- ❑ **Step 11:** Install the servo with the supplied 4-40 x .5” (Qty. 2) flat head screws. Tighten the screws all the way.
- ❑ **Step 12:** Install your original bellcrank system, and secure with the new steering brace provided and screws 4-40 x .375” (Qty. 2). Tighten the screws all the way.

- ❑ **Step 13:** Install your original chassis stiffener to the front bulkhead using your original front bulkhead hinge pin and e-clips. **Note:** If you purchased the “Pro” kit, use the new carbon chassis stiffener. See Section 7 for tuning details on the new chassis stiffener.

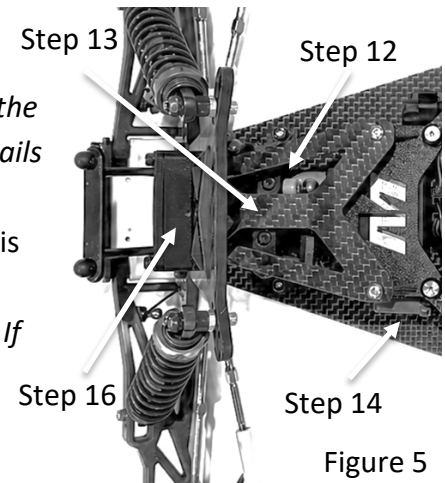

- ❑ **Step 14:** Secure the servo by installing your original chassis brace and secure by lowering the top plate and using the supplied 4-40 x .875” (Qty. 2) button head screws. **Note:** If you purchased the “Pro” kit, use the new chassis brace.
- ❑ **Step 15:** Install your original front bumper using your original 4-40 (Qty. 4) flat head screws. **Note:** If you purchased the “Pro” kit, use the new carbon infused bumper.
- ❑ **Step 16:** Install the front body mount using the provided 9mm extension. Secure with the supplied 4-40 x .75” (Qty. 2) socket cap and nuts.

XXT² Top Deck:

- ❑ **Step 16:** Install both the left and right top deck using the provided hardware. **Note:** the top plates are identical and can be used on either side.
- ❑ **Step 17:** Use 4 of the supplied 4-40 x .5” button head screws to secure the top deck to the center standoffs. **Note:** We DO NOT recommend using Loctite on these screws as they are a tuning option!

- ❑ **Step 18:** Install your original rear bulkhead, and secure with your original 4-40 x .375" (Qty. 2) flat head screws to the chassis. Tighten the screws all the way.
- ❑ **Step 19:** Use 2 of the supplied 4-40 x .5" flat head screw and black countersunk washers to secure the rear bulkhead to the rearmost standoff. Tighten the screws all the way. **Note:** We suggest using a small amount of blue Loctite on the screws.
- ❑ **Step 20:** Use 2 of the supplied 4-40 x .5" button head screw to secure the top deck to the remaining rear standoff. Tighten the screws all the way. **Note:** We suggest using a small amount of blue Loctite on the screws.
- ❑ **Step 21:** Use 2 of the supplied 4-40 x .5" flat head screw and black countersunk washers to secure the top deck to the center chassis support.

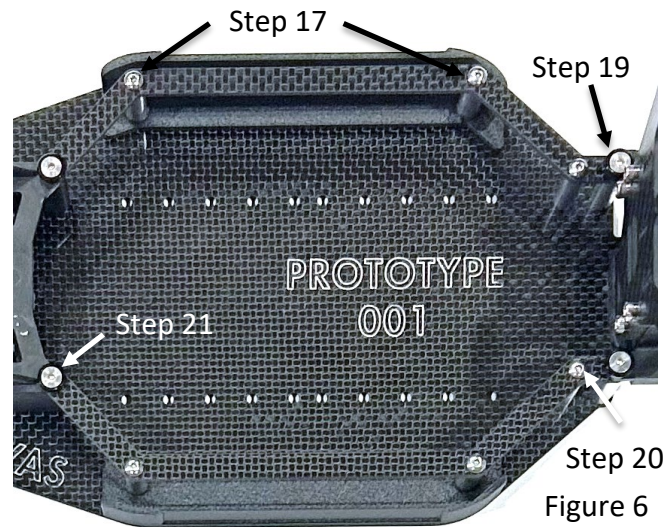

Figure 6

XXT² Rear End:

- ❑ **Step 22:** Install your original rear shock tower to the bulkhead, and secure with your original 4-40 cap head screws to the chassis. Tighten the screws all the way. **Note:** If you purchased the "Pro" kit use the new 2-n-1 rear tower and supplied 4-40 x .5" (Qty. 4) socket cap screws. See installing big bore section below for further details.
- ❑ **Step 23:** Install your original rear suspension mount and rear arms to the chassis, and secure with your original 4-40 flat head screws to the chassis. Tighten the screws all the way.
- ❑ **Step 24:** Install your original gearbox and remaining drivetrain components, and secure with your original 4-40 flat head screws to the chassis. Tighten the screws all the way. **Note:** If you purchased the "Pro" kit use the new tranny brace and the 4-40 x .5" cap head screws. See installing motor centering kit section below for further details.

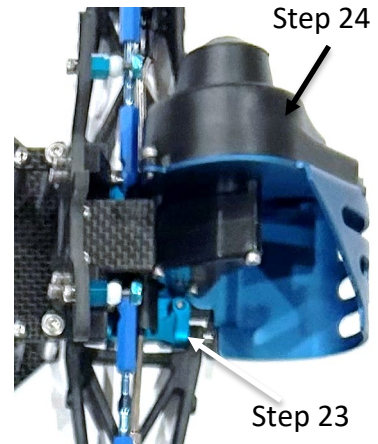

Figure 7

XXT² Suspension

- ❑ **Step 25:** Install your original turnbuckles. **Note:** See setup sheet and tips section for recommendations
- ❑ **Step 26:** Install your original shocks. **Note:** See setup sheet and tips section for recommendations.

□ Congratulations you have completed your new XXT²!

4. Mounting Electronics on your XXT²

Your new XXT² offers a variety of options and locations to optimally install your receiver, speed controller and any other electronic devices. The options will depend on the size of your equipment and the optimal weight distribution layout for your track, *see Battery Mounting section*. We have found the inline electronics installation on your chassis to work best across a variety of racing surfaces, as it allows you the most

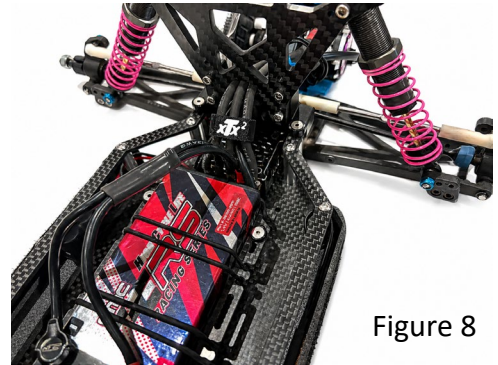

Figure 8

flexibility to run the battery inline or in the traverse direction. In this configuration, the receiver is located behind the servo, and the speed controller is mounted underneath the rear shock tower. As an option, you will find a black plastic rectangular part 45mm x 20mm. This optional piece is to be placed underneath the rear tower and secured to the rear bulkhead with double-sided tape (not included). This part provides extra protection for your ESC from any debris you may pick up at the track. **Note:** *If you purchased the “Pro” kit, the new 2-n-1 rear tower has cutouts for motor and sensor wires.*

For those of you that run primarily on one type of surface (i.e. loose dirt, carpet, ...), you may want to try different configurations to better suit your application.

5. XXT² Battery Mounting Options

When designing the MV XXT², improving the weight distribution was our primary objective. This is one of the most important tuning options on your new XXT² and your vehicle can be configured in an inline or traverse configuration.

Battery Type

Inline vs Traverse

The original Team Losi XXT offered an inline battery configuration with the option to move the battery forward or backwards as a tuning option. On the XXT², we have increased the inline spacing, further allowing a more forward or rearward battery position. Additionally, the one-

XXT²

piece inline battery brace offers both a large step inline positions options by repositioning the standoffs on the chassis, as well as micro tuning through the brace itself. Together, the XXT² allows you to precisely position your battery. The one-piece battery brace is secured using 4 of the supplied 4-40 x .375" flat head screws and aluminum countersunk washers. The battery is secured through the three supplied o-rings.

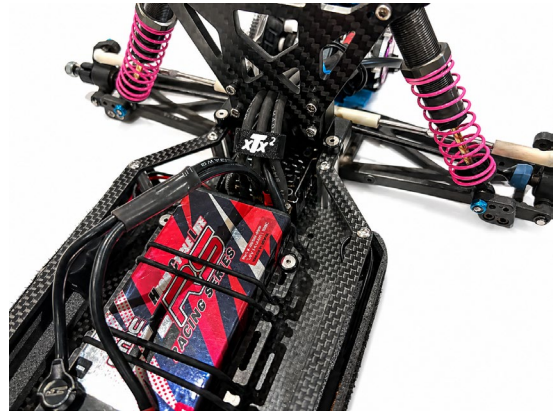

The XXT² also offers the ability to run the battery in the traverse configuration. This new feature changes the driving dynamics of the car and enables the forward most battery position configuration. The traverse battery position uses the supplied battery tabs, installed with the tabs towards the center of the chassis. The tabs are secured using 4 of the supplied 4-40 x .375" flat head screws and aluminum countersunk washers. The battery is secured with two of the supplied o-rings. **Note:** *The XXT² side guards are functional guards and have been designed to secure the battery from shifting side-to-side.*



Independent of your preference, we encourage you to start with the inline mount, as it most resembles the dynamics of the original Team Losi XXT. Don't be afraid to try both configurations, you will be amazed at how responsive this tuning option is.

Battery Type

The MV XXT² allows you to use a variety of 2S shorty LiPo to further expand the tunability of your race vehicle. If you are using a low center of gravity (LCG) pack (<20mm) use the two smaller battery o-rings supplied to ensure a secure fit. If you are using a standard shorty battery (>20mm), we recommend you use the two larger battery o-rings supplied. **Note:** *This applies to both the inline and traverse configuration.*

Please be sure to check your ride height if you are testing different battery types, as the weight difference between the LCG and standard pack can be quite different.

6. XXT² Body

We are proud to have worked closely with Boki to offer a XXT² body based on the original XXT CR body. A new mold was manufactured and specifically for the XXT² to accommodate the new



carbon chassis. **Note:** Your existing Team Losi XXT body will not work properly given the lower side sections of the XXT², but certainly can be used if needed!

Painting and Cutting your XXT² Body

Be sure to paint your new Boki XXT² body all the way down to the lower side flap on the shell. The lower side flap represents your revised lower body cut line.

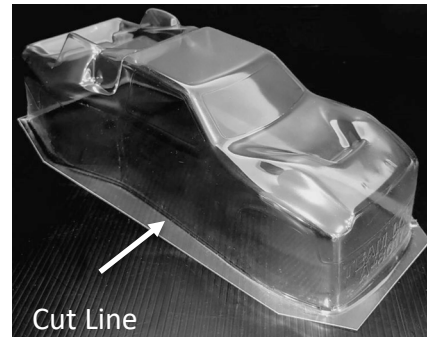

7. XXT² Elite Kit

Thank you for purchasing the MV XXT² Pro kit! The pro kit was developed with the ultimate vintage racer in mind further increasing the tunability, performance and experience! Below ...

2-n-1 Shock Tower and Wing Mount

The new XXT² 2-n-1 rear shock tower was developed to allow for an unprecedented set of tuning options all within one design, while preserving the original shock mounting positions. The 4mm carbon tower can be installed in the upper position when using the original Team Losi shocks or installed in the lower center of gravity (LCG) position (-8mm) to accommodate the shorter Big Bore shocks commonly used in today's modern trucks. **Note:** If you are installing Big Bore shocks, the 3mm spacer is included to move the tower forward to allow for shock clearance.

Big Bore Shocks

The MV XXT² can accommodate Big Bore shocks and either the Team Losi Racing (TLR) or Team Associated (AE) shocks can be used. Independently, the Pro kit does not include the components needed to install the Big Bore shocks as they differ by manufacturer. **Note:** The MV XXT² 2-n-1 tower is needed to accommodate the Big Bore shocks.

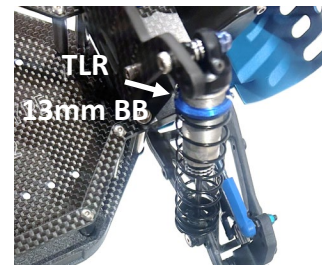

Adjustable Chassis Stiffener

The MV XXT² comes with the recently released Adjustable Front Chassis Stiffener. The new stiffener offers the ability to further tune your race truck by easily allowing you to adjust front kickup from the standard 30 degrees to either 27.5 or 25, by simply replacing the inserts provided. By simply switching the offset insert, you can get either 30 or 25 degrees, or use the optional centered one, to achieve 27.5 degrees. We recommend starting with 30 degrees - offset insert with hole forward!

XXT²

Motor Centering Kit

The MV XXT² Pro kit comes with the recently released Z3D Team Losi XXT motor centering kit to further improve the side-to-side weight distribution of the vehicle. This kit requires a slight modification to your existing motor plate and includes a template to perform the task.

Note: Use the QR code to download the instructions for proper installation.

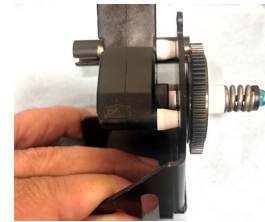

8. Finished!

Enjoy your new *Modern Vintage XXT²*, and be sure to follow us on Facebook, Instagram and YouTube!

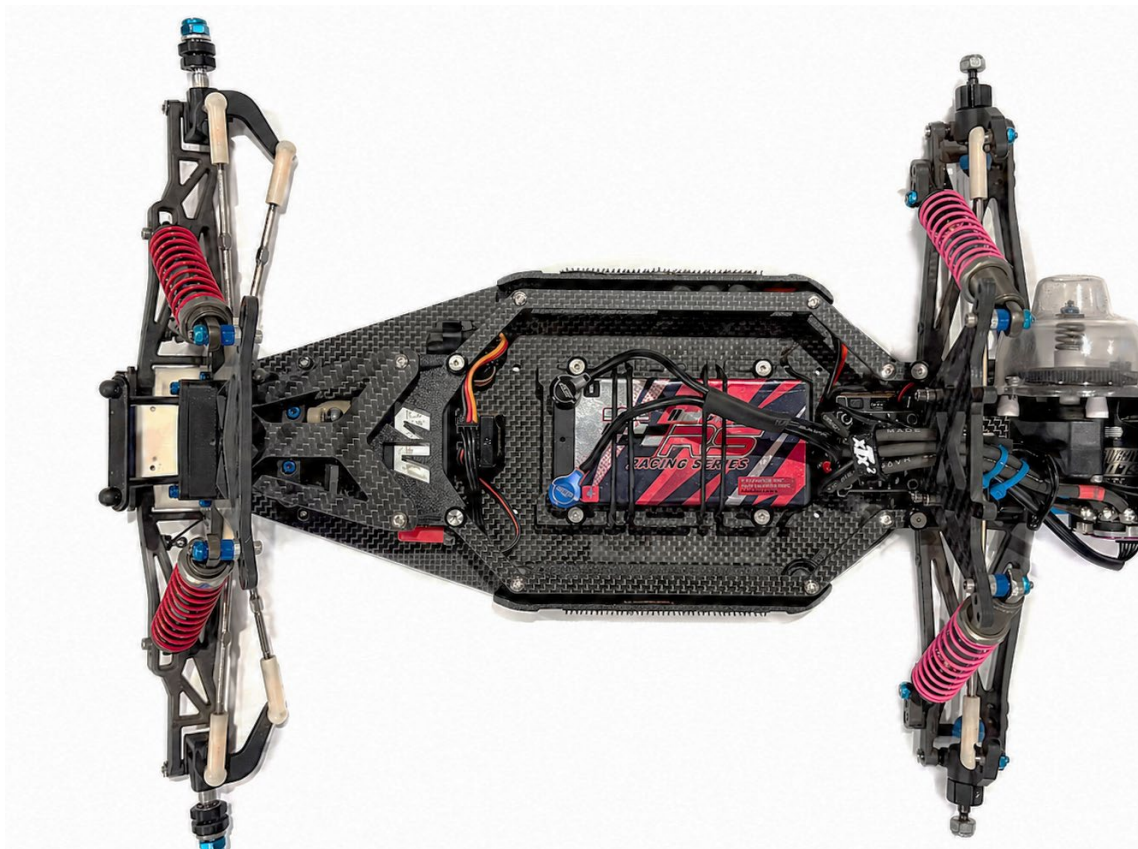

9. Addendum from the Team Losi XXT CR Manual

FINAL CHECKLIST

BEFORE RUNNING YOUR DOUBLE-XT 'CR' GRAPHITE PLUS for the first time, you should run down the following checklist – in order – and complete the listed tasks. I'm sure you're anxious to get out and run your Double-XT 'CR' *Graphite Plus* now that it's built, but following this simple checklist will help to make your first run with your new truck much more enjoyable.

1. Adjust the differential

See *About The Differential* in the tips section.

2. Adjust the slipper

See *Adjusting the Slipper* in the tips section.

3. Check for free suspension movement

All suspension arms should be very free. Any binds will cause the truck to handle poorly. The steering should also operate very freely.

4. Set the rear ride height

The rear ride height should be set so that the CVD drive shafts are level with the surface. See the *Ride Height* section of the tips.

5. Set the front ride height

The front ride height should be set so that the front suspension arms are level with the surface. See the *Ride Height* section of the tips.

6. Adjust the camber

The front camber should be set to 1-1/2 degrees of negative camber (top of tire points in) at ride height. Adjust the front camber with the tire turned straight ahead. The rear camber should be set to have about 2 degrees of negative camber at ride height. See the *Camber Adjustment* section of the tips.

7. Set the front toe-in

Adjust the front tie rods so that when the steering is straight on the transmitter, the front tires are both pointing inward just slightly (*toe-in*). It is recommended that you start with about 1/2 degree of toe-in at each front tire.

8. Charge a battery pack

Charge a battery pack as per battery manufacturer's and/or charger manufacturer's instructions so that radio adjustments can be made.

9. Adjust the speed control

Following the manufacturer's instructions, adjust your speed control and set the throttle trim on your transmitter so the truck does not creep forward when no throttle is being applied. Also, make sure that there is not too much brake being applied when the trigger/stick is in the neutral position.

10. Set transmitter steering trim

The steering trim tab on the transmitter should be adjusted so that the truck rolls straight when you are not touching the steering wheel/stick.

TIPS AND HINTS FROM THE TEAM

About The Differential Never allow the diff to slip; that's what the slipper is for. Before trying to adjust your diff, you need to tighten the slipper until the spring is fully compressed. Next, hold the spur gear and right rear tire, then try turning the left rear tire forward. It should be very difficult to turn the left rear tire. If the tire turns easily, the diff is too loose. To tighten the diff, line up the slot in the diff screw with the groove in the left outdrive. Place the 1/16" Allen wrench through both of these slots. This will lock the diff screw and the outdrive together. While holding the Allen wrench in place, turn the right rear tire forward about 1/8 turn. Check the differential adjustment again and repeat the tightening process as necessary until the differential is no longer slipping. The final differential adjustment check should be made by placing the truck on carpet, grass, or asphalt and punching the throttle. The differential should not slip. If it does, tighten the diff in 1/8-turn increments as described above until the slippage stops.

Once the diff has been adjusted, it should still operate freely and feel smooth. If the diff screw starts to get tight before the diff is close to being adjusted properly, the diff should be disassembled and inspected; you may have the bearings in the diff installed in the wrong locations. Consult the assembly instructions for locations of various sizes of bearings in the differential.

There are a few things you should know about differentials. First, when rebuilding your diff, you should always replace the small 4-40 locknut. Second, after the diff has been built for a couple of hours, or been run a time or two, it is not uncommon for the balls to seat into the rings and create a slightly loose adjustment. So, after your first run, check the



adjustment to avoid slippage. Third, remember: Never let the diff slip. Doing so can damage the diff balls, rings, and gear. Always make sure that the slipper will slip before the diff.

Adjusting the Slipper should be done after the diff is properly adjusted. If you have just finished adjusting the differential, loosen the slipper adjustment nut four full turns (e.g., 360 degrees x 4) to return the adjustment to the setting originally described in the assembly instructions. To make the final adjustments, place your truck on the racing surface and give the truck full throttle. The slipper should slip for one or two feet at the most. If the slipper slips for more than two feet, you'll need to tighten the adjustment nut. If it doesn't slip for at least one foot, back off the adjustment nut 1/8 turn and retry. If you can't hear the slipper when you punch the throttle, hold the front of the truck with the rear wheels still on the track surface and give the truck full throttle. The truck should push against your hand with reasonable force and the slipper should slip slightly.

Don't expect the slipper to make up for poor driving. You still have to use your throttle carefully. The slipper will, however, give you a little help coming off corners and landing jumps.

When the track is really rough, rutty, or has a lot of killer jumps, you may want to consider installing a Hydra-Drive unit. When using the Hydra-Drive, the slipper adjustment should be set a bit looser so that the spur gear is easier to rotate while holding the right rear tire. Use the same method of checking adjustment on the Hydra-Drive as you would on the standard friction slipper. Do not run the Hydra-Drive too loose; it will build up heat and eventually damage the seals. The standard fluid should be used most of the time in the Hydra-Drive. This kit has a different type of slipper that cannot be used with the Hydra-Drive as it sits. However, a Hydra-Drive unit can be fit to the shaft by replacing the gear and outside aluminum slipper back plate with the Hydra-Drive spur gear, gear plate, Hydra-Drive unit, spring, etc.

Ride Height is an adjustment that affects the way your truck jumps, turns, and goes through bumps. To check the ride height, drop one end (front or rear) of the truck from about a 5-6 inch height onto a flat surface. Once the truck settles into a position, check the height of that end of the truck in relationship to the surface. To raise the ride height, evenly lower the shock collars on the shocks on the end (front or rear) of the truck you are working on. To lower the ride height, raise the spring collars. Again, both left and right collars should be adjusted evenly.

You should start with the front ride height set so that the front suspension arms are level. Occasionally, you may want to raise the front ride height to get a little quicker steering reaction, but be careful as this can also make the truck flip over more easily. Run the rear ride height set so that the truck comes to a rest at a height that is right in between having the arms level and the dogbones level with the surface. Every driver likes a little different feel and should try small ride height adjustments to get the feel he likes. We have found that ride height is really a minor adjustment. Play with it last after everything else has been dialed in. Do not use ride height adjustment as a substitute for a spring rate. If your truck needs a softer or firmer spring, change the spring. Do not think that simply moving the shock collar will change the stiffness of the spring; it won't!

Camber Location is best set according to the settings described in this manual. Leave the rear inner location at #5 and start with the 'B' location in the rear hub. Move the ball stud to the 'C' location in the hub for a slightly stiffer feel. The 'C' location seems to have a bit more roll resistance than the 'B' location, but tends to give you slightly less steering out of the corners. Start with the front camber link in the inside hole in the front shock tower as this is a pretty good starting point for most tracks. Occasionally, you may want to move the camber link out one hole if there isn't enough steering when entering a turn. The shorter camber link tends to make the steering response a little more sensitive.

Kingpin Balls are adjustable and can affect the front camber location as well. By moving washers from the top of the spindle carrier to the bottom, the ball stud can be lowered. Lowering the ball stud will usually make the steering react a little faster, but can reduce the amount of low-speed steering the truck has.

Some of the team drivers like to file the small raised area off of the top of the spindle carrier when using the kingpin/ball studs. This will broaden the range of adjustment that is available. In very slick conditions, you may want to try mounting the kingpin/ball stud all the way down flat against the top of the spindle carrier. Doing so can increase the



traction at the front of the truck which results in a gain of steering.

Front Shock Location can be adjusted easily by simply moving top of the shock to another hole in the shock tower. The standard location (inside hole on the tower) works best on most tracks. Moving the top of the shock out one hole can help to keep the nose of the truck a little higher on large, difficult jumps. The bottom of the shock is almost always mounted in the center hole in the arm.

Rear Shock Location can be changed just as easily as the front. Again, the standard location is the best place to start for most tracks. Moving the top of the shock out on the shock tower can help the truck land better on big jumps, but may also make the truck drive “square” with more forward traction and less cornering speed and side bite. The bottom of the shocks are almost always mounted to the center hole of the bottom shock mount. Try the inside hole if you’re on a really rough track, but be aware that there is usually less cornering traction.

Rear Toe-In and Anti-Squat are two more things you should try and need to adjust based on what you feel is most comfortable to you. The standard kit setup is usually the best. The stock setup has two degrees of anti-squat. You can change this to zero degrees by changing the rear pivot block – another neat thing about the Double-XT ‘CR’ *Graphite Plus*. Less anti-squat will help the truck accelerate through the bumps, but may also decrease rear traction and steering through the corners. More importantly, less anti-squat is usually more predictable under braking or while de-accelerating, which on some tracks makes a big difference.

The rear toe-in is set stock at three degrees per side, or six degrees total. This helps the truck accelerate straighter, and this setting works well on nearly all tracks.

Rear Hub Spacing can be adjusted by moving the spacers at the front and rear of the hub carrier. You will probably find that the middle (standard) location works best on just about every track. Spacing the hub back might help on large, high-speed, outdoor tracks. Spacing the hub forward might help on tight, indoor tracks.

Battery Location is sometimes overlooked. Start by running the battery spaced 1/2"-5/8" back from the front brace. Moving the battery back farther will increase rear-wheel traction, but can decrease steering. Moving the battery forward will increase steering, but can cause the rear of the truck to have too little traction.

The Secret to winning is realizing that there are no magic pieces or secret setups that are going to make you faster. There is no substitute for practice and experimenting with different things. The feel for the way the truck handles is different for every driver. The only way you will get the right feel for you and your truck is to make adjustments and note the effects that those adjustments have on your truck’s handling. The more adjustments you try, the more you will learn about the truck and how it reacts. Make notes about the track conditions and which changes produced good or bad results. You may have to sacrifice a tenth of a second to end up with a truck that is comfortable to drive fast and consistent.

We are sure that you will find the Double-XT ‘CR’ *Graphite Plus* to be the most versatile and easiest truck to drive fast with great consistency. We at Team Losi hope this information helps you to enjoy your Double-XT ‘CR’ *Graphite Plus* and racing as much as we do.

scan courtesy of Vintagelosi.com



XXT²



Our Story: At Modern Vintage Racing we are committed to providing the racing community with high quality vehicles that are not only designed to endure the requirements of today's racing environment, but also honor their heritage, design and history! The XXT² represents just the beginning, and we thank you for your trust in us. Stay connected with the XXT² community!

