



SET-UP SHEET

DRIVER: _____

DATE: _____

EVENT: _____



FRONT SUSPENSION

FRONT SPINDLE CARRIERS: 25°, 30°

TOE-IN / TOE-OUT: _____°

FRONT RIDE HEIGHT: _____

FRONT CAMBER: ± _____°

SWAY BAR: NO, YES: _____

NOTES:

FRONT SHOCKS	<input type="checkbox"/> ORIGINAL	<input type="checkbox"/> BIG BORE
OIL: _____		
SPRING: _____	<input type="checkbox"/> DRILLED	<input type="checkbox"/> STANDARD
SPRING: _____	STROKE: _____	
LIMITER: INSIDE: _____	OUTSIDE: _____	

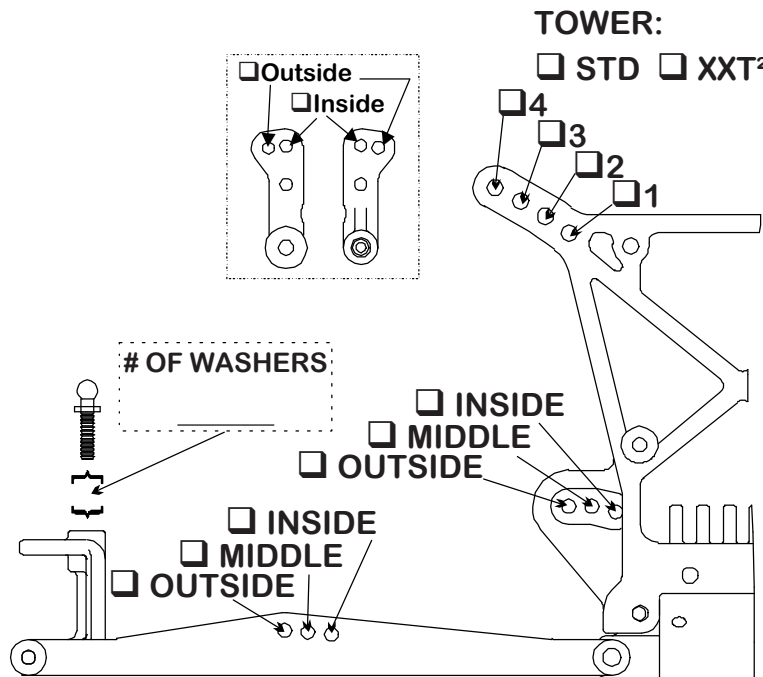

REAR SUSPENSION

ANTI-SQUAT: _____ TOE-IN: _____°

REAR RIDE HEIGHT: _____

REAR CAMBER: ± _____°

SWAY BAR: NO, YES: _____

DRIVE SHAFTS: CVDs, UNIVERSAL

NOTES:

REAR SHOCKS	<input type="checkbox"/> ORIGINAL	<input type="checkbox"/> BIG BORE
OIL: _____		
SPRING: _____	<input type="checkbox"/> DRILLED	<input type="checkbox"/> STANDARD
SPRING: _____	STROKE: _____	
LIMITER: INSIDE: _____	OUTSIDE: _____	

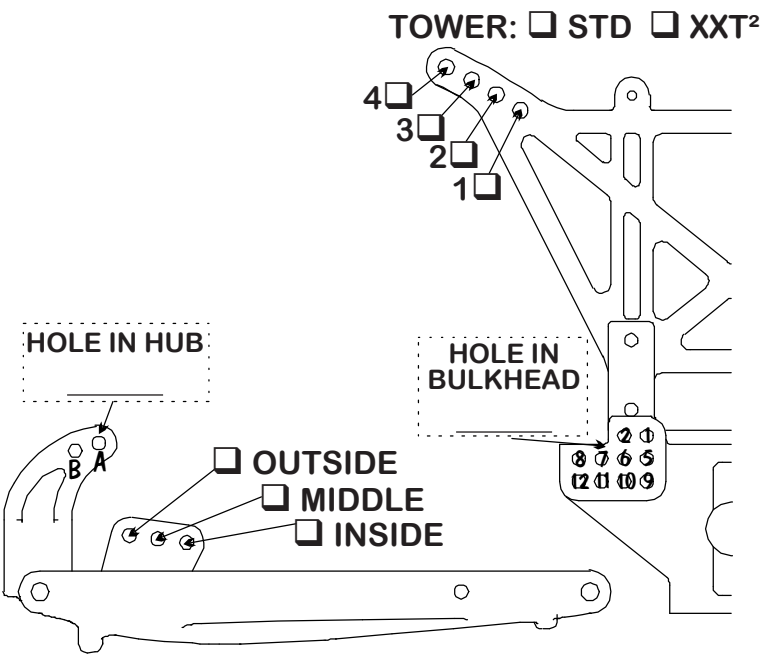

TRANSMISSION & CHASSIS

FRONT TIRE: _____ COMPOUND: _____ TRANSMISSION: 2.19, 2.61

REAR TIRE: _____ COMPOUND: _____ MOTOR: _____

CHASSIS: SHORT, STANDARD, LONG, X-LONG PINION: _____ SPUR: _____

BATTERY: _____ LOCATION: _____ MOUNT: _____

NOTES: